

A man with a beard, wearing a brown cap and jacket, sits in a rugged, mountainous landscape. He is holding a large rifle with a scope and binoculars. In the foreground, the head and antlers of a hunted animal are visible. The background shows rocky terrain and mountains under a blue sky.

# SCHULTZ & LARSEN

Sporting Rifle User Manual



# SCHULTZ & LARSEN



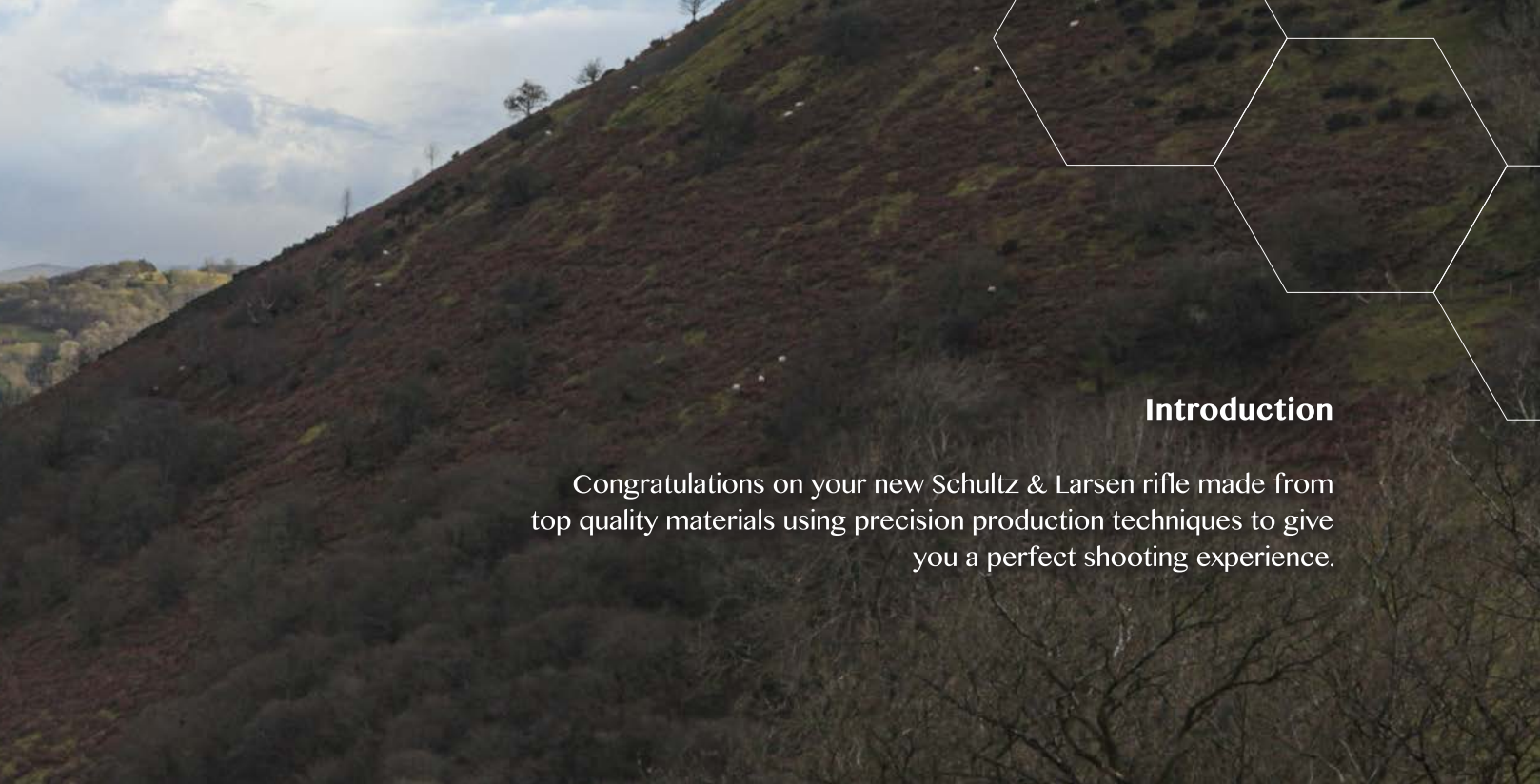

## **Introduction**

Congratulations on your new Schultz & Larsen rifle made from top quality materials using precision production techniques to give you a perfect shooting experience.



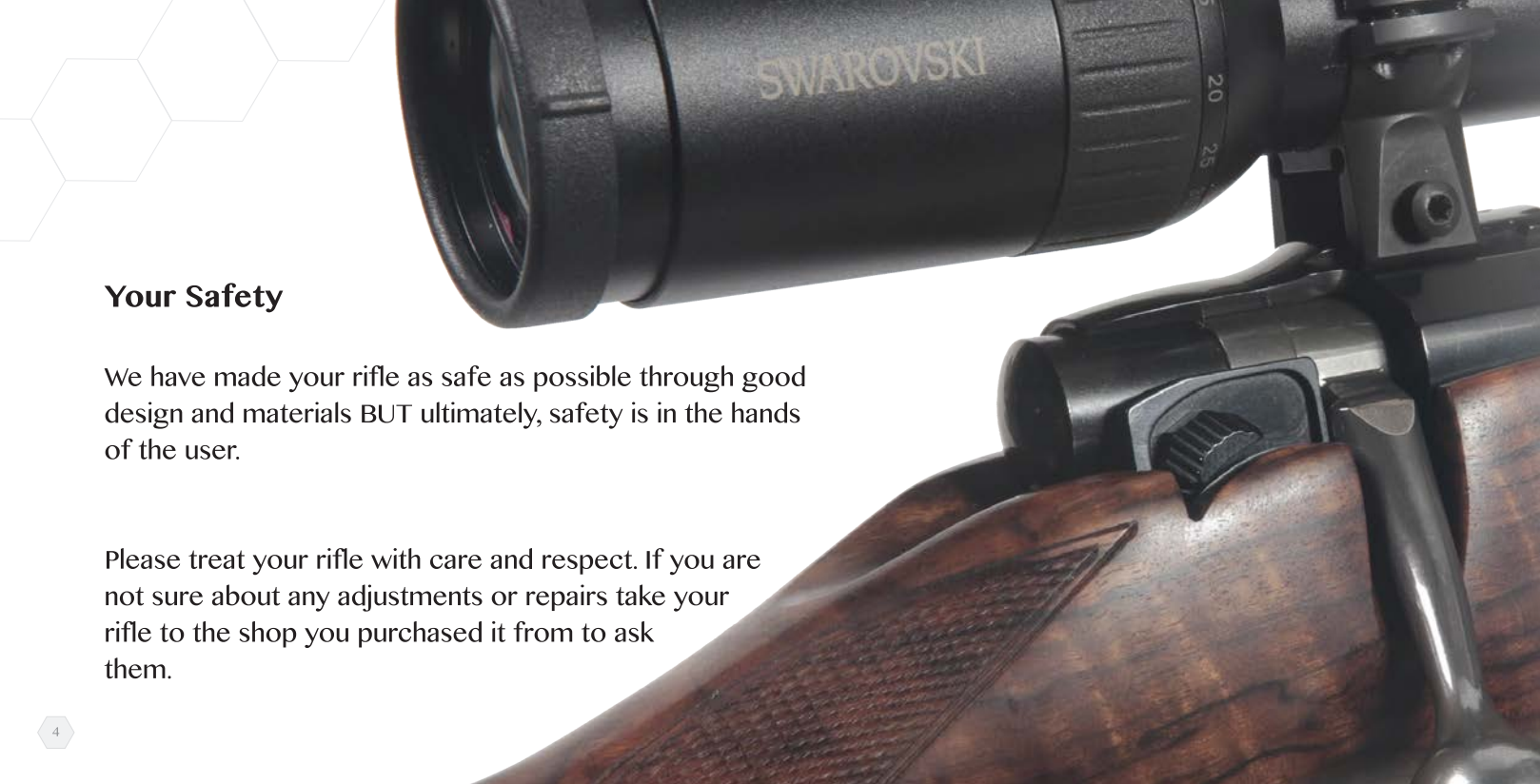

## Your Safety

We have made your rifle as safe as possible through good design and materials BUT ultimately, safety is in the hands of the user.

Please treat your rifle with care and respect. If you are not sure about any adjustments or repairs take your rifle to the shop you purchased it from to ask them.



## The Safety Catch

Your rifle has a three-position safety.

The rear position, blocks the operation of the firing pin and the bolt.

The middle position blocks the operation of the firing pin but allows unloading of the rifle whilst engaged.

The forward position allows you to fire.

Do not touch the trigger whilst moving the safety.

Do not intentionally pull the trigger whilst the safety is engaged.

Remember no mechanical device is infallible.

Keep good gun discipline at all times.



Rear position



Middle position



Forward position

## The Bolt

Your rifle is shipped with the bolt removed. If you have both Magnum and Standard bolts because you have extra barrels in different calibres ensure that you are installing the correct bolt for that calibre.



To identify which is a standard or a magnum bolt simply look at the bolt face and you will see that the recess is of a bigger diameter on the magnum than on the standard.

Later bolts have a “S” or an “M” stamped on the front of one of the locking lugs.

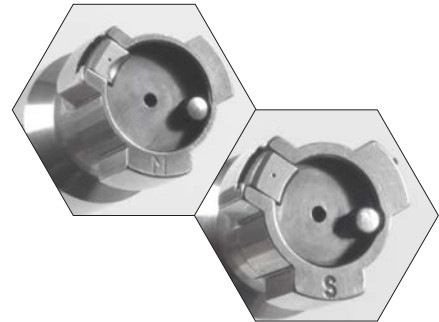

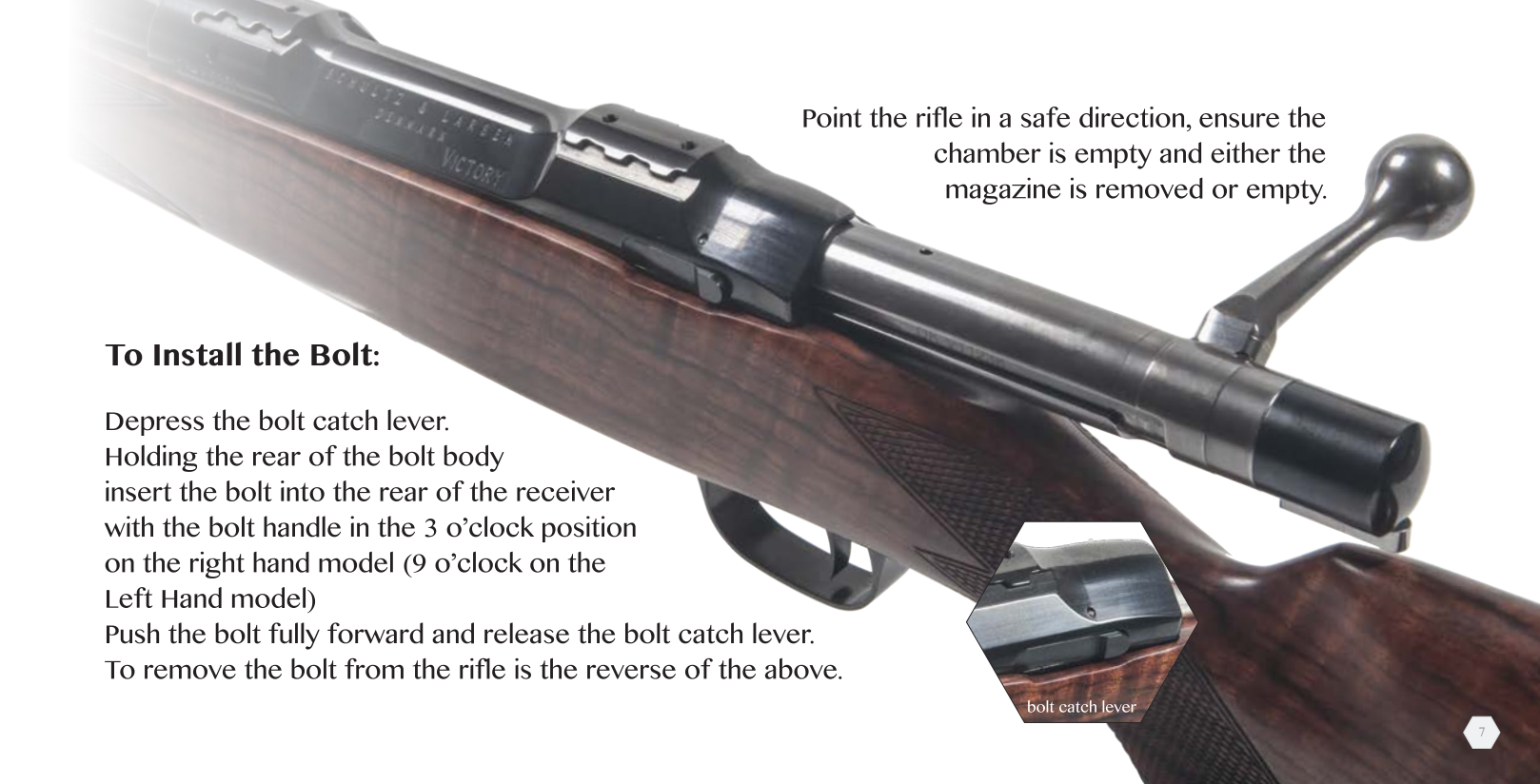

Point the rifle in a safe direction, ensure the chamber is empty and either the magazine is removed or empty.

### **To Install the Bolt:**

Depress the bolt catch lever.

Holding the rear of the bolt body insert the bolt into the rear of the receiver with the bolt handle in the 3 o'clock position on the right hand model (9 o'clock on the Left Hand model)

Push the bolt fully forward and release the bolt catch lever.

To remove the bolt from the rifle is the reverse of the above.

bolt catch lever





Magazine  
Release

## The Magazine

The magazine is removed by firmly pressing the magazine release button, this is found just in front of the magazine. Simply pull the magazine straight out.

To reinstall the magazine place the magazine squarely into the magazine well, then gently but firmly continue to press the magazine into the well until the catch engages.

The magazine normally requires no servicing or adjustment. There are four different magazine sizes. They are marked at the back of the magazine with a letter denoting what calibres it can take.



## Magazine Options

| Calibre       | Magazine | Bolt |
|---------------|----------|------|
| 22-250 Rem    | K        | STD  |
| .243 Win      | K        | STD  |
| 6mm BR.       | 1 Shot   | STD  |
| 25.06         | L        | STD  |
| 6.5x55        | L        | STD  |
| 6.5-284       | L        | STD  |
| 6.5 Creedmoor | K        | STD  |
| .270 Win      | L        | STD  |
| 7x57          | L        | STD  |
| 7x64          | L        | STD  |
| 7mm-08        | L        | STD  |
| .308 Win      | K        | STD  |
| .30-06        | L        | STD  |
| 9.3x62        | L        | STD  |

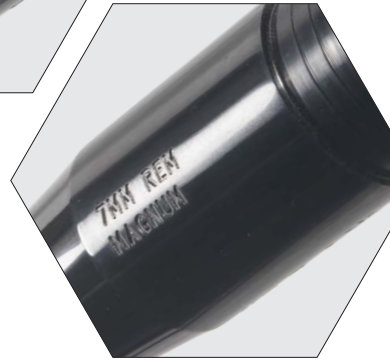
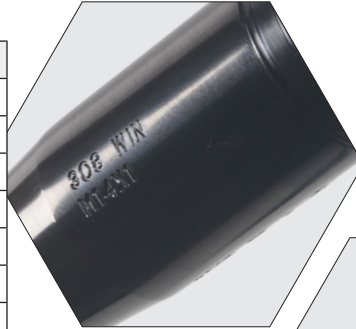

| Calibre        | Magazine | Bolt |
|----------------|----------|------|
| .270 WSM       | KM       | MAG  |
| 7mm Rem Mag    | M        | MAG  |
| 7mm WSM        | KM       | MAG  |
| .300 Win Mag   | M        | MAG  |
| .300 WSM       | KM       | MAG  |
| .338 Win Mag   | KM       | MAG  |
| .358 Norma Mag | M        | MAG  |
| .375 Ruger     | M        | MAG  |
| .416 Taylor    | M        | MAG  |
| .458 Win Mag   | M        | MAG  |

K = Short  
 L = Long  
 M = Magnum  
 KM = Short Magnum

## The Barrel

Our barrels are of outstanding quality. We are very proud of the accuracy of our barrels, as you will be too. Clean after using the rifle or when you have been out in wet conditions with patches and good quality gun oil from the chamber end to the muzzle.

We do not recommend cleaning the bore with solvents.

## The Barrel Switch System

By switching barrels your Schultz & Larsen rifle has the ability to shoot a range of different calibres. You may have to order a different bolt and/or magazine when using an extra barrel.



Octagonal, Fluted or  
Spiral Fluted Barrel Profiles are  
available with selected calibres



## Cleaning, Lubrication and Servicing

Proper cleaning and lubrication is important to ensure your rifle maintains its accuracy, safety and reliability.

Normally all that is required to clean your rifle is to wipe all metal surfaces with a soft, clean, lightly oiled cloth using a good quality gun oil.

The stock can benefit from occasional rubbing in of a thin coat of linseed oil use your bare hand or a soft clean cloth to rub in. Take care not to get the linseed oil on the metal parts.

We do not recommend cleaning the bore with solvents.

Only a qualified gunsmith should service or adjust your rifle.



## Barrel Removal

Action  
Screws

Open the bolt and remove it from the rifle. The bolt locks into the barrel and it is not possible to remove the barrel with the bolt closed and engaged.

Remove both action screws located in the bottom plate beneath the rifle using a 4mm Hex wrench. Lift the barrelled action off the stock.

The Barrel Locking Screws are visible on the right hand side at the front of the action. Using the same 4mm Hex wrench slacken the front screw first, followed by the rear. It is not necessary to slacken the screws more than 1/2 turn.

Barrel  
Locking  
Screws

Holding the action, grasp the barrel firmly and slide it forwards from the action.

slide barrel forwards

## Barrel Replacement

Insert the barrel into the front of the action. There is a notch in the underside of the barrel breech that aligns with a stud in the action. Slide the barrel back firmly into the action and rotate gently until the stud drops into the notch and the barrel comes fully back onto the action. As a visual aid, the notch aligns with the stud when the barrel serial number is at the top.

Close the bolt. Closing the bolt positions the barrel correctly and sets the head space prior to tightening the Barrel Locking Screws.

Tighten the Rear Barrel Locking Screw first and the Front Screw second.

Do not tighten either incrementally. Tighten Rear Screw fully and then the Front Screw fully. Do not over-tighten. Best practice is to loosely turn the screw down until it makes contact and then tighten a further 1/8th of a turn.







Replace the barrelled action carefully onto the stock making sure the action is sitting fully down onto the steel bedding blocks. Keeping the action in position on the stock with the palm of the hand, turn the rifle over. Replace the bottom metal if you removed it.

Insert both action screws and spin down the first until it makes gentle contact. Spin down the second screw in the same way.

Now, tighten the first screw 1/8th of a turn and repeat with the second. Return to the first and nip a further 1/16th of a turn and repeat with the second.

As all Schultz & Larsen rifles are pillar bedded, correct tightening is less critical than it would be on none pillar bedded rifles, nevertheless, it is good practice to acquire the feel for tightening both screws evenly and to the same torque. It is not good practice to tighten one screw down with as much force as you can before doing the same with the other.

**Please Note:** If you are changing a Standard calibre barrel to a Magnum calibre barrel or vice versa, make sure you change the bolt accordingly. Standard calibre bolts are marked with an ‘S’ on the face of the bolt and Magnum calibre bolts are marked with an ‘M’.

After refitting the barrelled action to the stock, check all functions.

**IMPORTANT:** Check the rifle is unloaded and the magazine empty before carrying out any function checks. Open and close the bolt, operate the safety and ensure that in the back position the bolt is locked and the trigger inoperative. In the centre position, the trigger should remain inoperative but the bolt should open. In the forward position, the bolt should open and the rifle should fire when the trigger is pulled.

If, during the function checks, anything does not work as expected or feels different from usual, remove the stock again and carry out a function check without the stock. If all works normally the most likely cause is tightening the action onto the stock when it is not sitting fully on the bedding blocks. If you cannot rectify this yourself please call either your supplying dealer.

## Changing the Barrel with the Traveller Conversion

Holes with Access  
to Barrel Locking Screws

Front Action  
Screw

The Traveller Conversion is modification which can be made to any rifle and is the standard configuration on the Classic Synthetic for instance.

There are two holes in the right hand side of the stock to access the Barrel Locking Screws.

Insert the 4mm Hex wrench and into the barrels locking screws and slacken both screws  $\frac{1}{4}$  turn.

Using the same wrench, slacken the front action screw in front of the magazine  $\frac{1}{4}$  turn.

The barrel can now be slid forward into the barrel channel and lifted clear.

When re-fitting, insert the barrel with the notch facing down. Rotate gently whilst inserting the barrel collar into the action until the notch engages and the barrel goes fully home.

Close the bolt to set the head space.

Tighten the Rear Barrel Locking Screw fully, followed by the Front Barrel Locking Screw. **Do not over tighten.**

Lastly, tighten the Front Action Screw.

**Please note:**

That the barrel can only slide forward if there is sufficient clearance under the scope for the breech end of the barrel to pass under the scope. If your scope is fitted very low that it stops the barrel from being removed, you will need to detach the scope from the rifle to be able to remove the barrel.

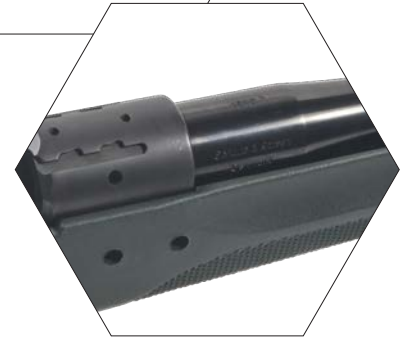

## The Adjustable Comb

The Synthetic Thumbhole stocks have adjustable combs, with height adjustment from 0 to 40mm.

The stocks feature rubber inlays on the grip and forearm for all weather use.





Adjustable Height  
0 - 40mm



The mechanism is spring loaded, so with a turn of the toggle on the right side of the stock, the comb lifts automatically.

To set the comb at the desired height, hold the comb in position, tighten the toggle, then press the front of the comb downwards to lock the position in place.

## The Direct Trigger (Single Stage Trigger)

The trigger is set at a safe weight when a rifle is sent out from us. Only adjust the trigger if you are confident that you can do so and always make several checks that it is safe before using live ammunition.

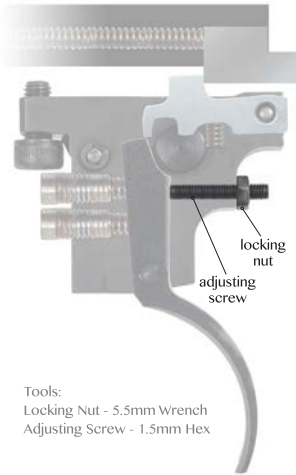

Tools:  
Locking Nut - 5.5mm Wrench  
Adjusting Screw - 1.5mm Hex

### Sear engagement adjustment

1. Insert the allen wrench into rear of the adjusting screw. Hold in position and slacken the lock nut.
2. With the wrench in the position with the long arm inserted in the screw, turn the screw with the short arm of the wrench clockwise very slowly until the bolt fires. Stop immediately. (if you twist the wrench too quickly you will turn the screw past the point at which the bolt fires.)
3. Remove the allen wrench and insert the short arm into the screw. This is for a clearer view of how much you are turning the adjusting screw.
4. Turn the adjusting screw  $\frac{1}{4}$  turn counter-clockwise, no less no more.
5. Hold the wrench firmly to stop the screw turning whilst locking the nut again.
6. Test for a Slam Fire. If it occurs, you will need to slacken the adjusting screw by a further  $\frac{1}{8}$  turn until you do not get a slam fire. **ALWAYS TEST FOR SLAM FIRE**

## Pull weight adjustment

There are two screws in the front of the trigger mechanism. Both have springs behind them. The top one is furthest away from the pivot point of the trigger so has the most effect.

Spring pressure adjustments should be made on the top screw only. The bottom screw is to ensure there is sufficient pressure on the trigger blade and should not be altered.

If you have altered this spring you can reset the position by screwing it in fully. At this point the trigger will be blocked. Unscrew slowly until the trigger blade can move again and unscrew a further  $\frac{1}{4}$  turn.

Adjust the pull weight using the top screw only. Screw in clockwise to make the trigger heavier. Screw out counter-clockwise to make the trigger lighter.

If you feel some creep in your trigger increasing the spring weight will make it feel more crisp.

**AT ALL STAGES YOU MUST TEST THOROUGHLY FOR SLAM FIRE.**

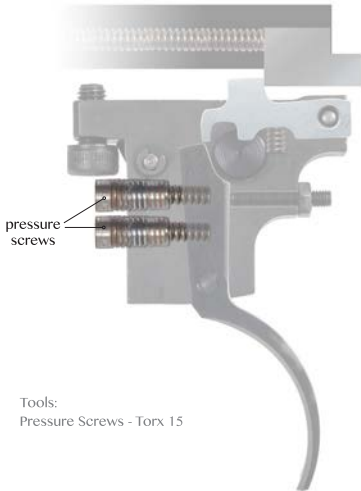

Tools:  
Pressure Screws - Torx 15

## The Match Trigger (Two Stage Trigger)

The Match Trigger has two stages in its operation. The first stage allows the trigger to travel with little resistance and set the sears ready. The second stage is a small movement, with a greater resistance, which disengages the sears from the firing pin and allows the rifle to fire.



Balancing the different screw lengths and weights to achieve a trigger pull suited to you will take time, but most importantly, spend time making sure it's safe to use. The ideal Match Trigger will have a sufficient amount of first stage travel and a crisp second stage.

### Travel adjustment for first stage

1. Insert the allen/hex wrench into travel screw.
2. Tighten this to create a shorter first stage travel. Too Tight and it will fire during the first stage.
3. Slacken this screw for a longer first stage travel. Too loose and it won't engage the lower sear and it will mean the second stage does all of the work.
4. Slacken the travel screw 1/2 turn from tight to ensure it doesn't fire during the first stage.

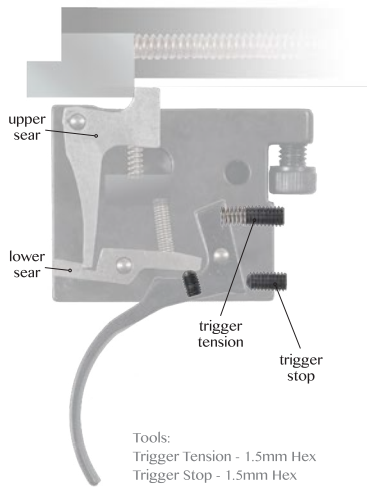

## Trigger tension adjustment

1. Insert allen wrench into trigger tension screw to adjust the tension behind the trigger.
2. Tighten the screw for more tension - **TOO TIGHT WILL BLOCK THE TRIGGER**
3. Slacken the screw for less tension - **TOO LOOSE WILL CAUSE A SLACK TRIGGER**
4. We would recommend leaving this screw at the factory setting

## Trigger resting position adjustment

The trigger stop screw alters the resting position of the trigger. Tightening this screw will set the resting position of the trigger rearwards, causing the first stage to become shorter.

If you do tighten this screw too much, it can shorten the first stage so much so that you are starting the trigger movement with the second stage. This is not recommended and can be dangerous if you are just using the second stage.

Slackening the screw will cause a longer first stage pull. Slackened too much and there will be trigger travel even before the travel screw engages with the lower sear.

## Schultz & Larsen 'Slide & Lock' Scope Mounts

Schultz & Larsen models, Classic, Hunter, Victory and Legacy are machined to accept the Schultz & Larsen made 'Slide & Lock' all steel scope mounts without the need for additional bases.

The individual slide & lock mounts are a one-piece steel construction, rust protected and hardened.

On the Classic and Victory, the mounts can be positioned in either a 'Summer' or 'Winter' position. The scope being able to move backwards to compensate for additional cold weather clothing whilst retaining the same eye relief.

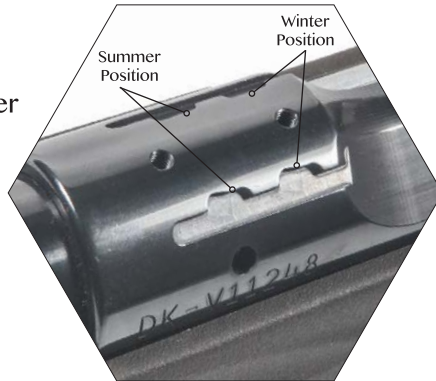

**Please note:** that the mount clamping screws must always be to the RIGHT-HAND SIDE of the action.

Available in various height options:

**1 inch:** 7mm / 11mm / 13mm / 16mm / 20mm BH

**30mm:** 7mm / 11mm / 13mm / 16mm / 20mm BH

**34mm:** 10mm / 13mm BH

**36mm:** 8mm / 11mm BH



## Fitting 'Slide & Lock' Mounts

To fit, simply position the mount over one of the two horizontal notches, press down evenly and slide forward until the mount is fully forward in that position. Tighten the clamp screw on the right and the mount is secure. If your mount is difficult to slide forward, check it is down evenly on both sides and engaged in the slots. If it is, firm pressure with the thumb at the rear of the mount will see it slide forward into position.

When fitting mounts to the rifle it is important that the clamping screws are NOT tightened at all before the mounts are in position on the action as this will almost certainly cause damage to the mount. It is recommended that the mount be positioned on the rifle and tightened in place before the scope is fitted to the mount. Set the scope in the correct position for eye relief. Replace ring caps and tighten cap screws in sequence, alternating right to left and front to rear. Do not tighten any screw fully but instead work them down in even stages. During tightening, check constantly that your reticule is vertical.



## Picatinny Rails and Weaver Bases

The Classic, Victory, Legacy and Ambassador models are all drilled and tapped to accept the Schultz & Larsen picatinny rails or individual weaver bases.

### Picatinny Rail Options:

- Legacy in 0 MOA or 20 MOA
- Classic in 0 MOA or 20 MOA
- Victory in 0 MOA or 20 MOA
- Ambassador in 0 MOA or 20 MOA

### Weaver Base Options:

- Classic
- Victory
- Ambassador

### Fitting Guide:

Please ensure that you clean and degrease the top of the rifle before fitting any mounts. Also check, clean and degrease the screws provided.

Use a suitable surface-to-surface adhesive for the rail to the rifle for bedding the rail to the rifle and for an additional bond. Also use a suitable thread locker adhesive on the screw threads to prevent recoil vibration from loosening the screws. Tighten screws to 3Nm and then remove any excess glue with alcohol before it cures.





**Achieving the Correct Mounting Height**  
With a picatinny rail or weaver bases, you are able to use various height rings to achieve your desired mounting height.



SCHULTZ & LARSEN